

FICHA TÉCNICA

KANIA

MONOMANDO BIDÉ

Color: Cromo



CÓDIGO: 102002002

Cartucho cerámico 35mm

Apertura suave

Conexiones flexibles cert-3/8

Peso: 0,53 Kg.

Peso embalaje: 0,91 Kg.

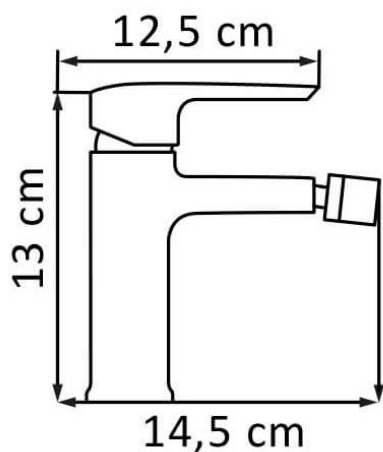

Designed in Europe



Anti-Cal
Anti-Scale



Cartucho Cerámico
Ceramic Cartridge



12u./Caja
12u./Box



Conexiones flexibles
Certified flexible



Montura cerámica
Ceramic cartridge



Fácil montaje
Easy assembly