

# FICHA TÉCNICA

## KARES

### MONOMANDO BIDÉ

Color: Cromo



**CÓDIGO: 102003002**

**Cartucho cerámico 35mm**

**Apertura suave**

**Conexiones flexibles cert-3/8**

**Peso: 0,88 Kg.**

**Peso embalaje: 1,12 Kg.**

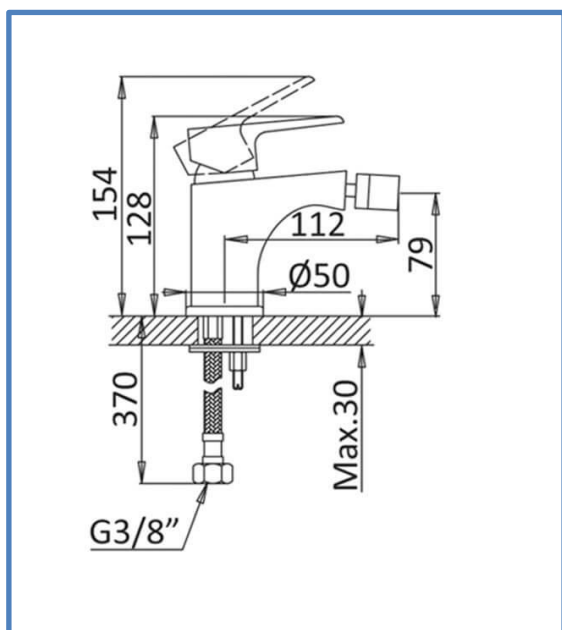
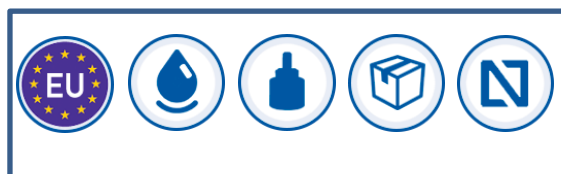

Designed in Europe



Anti-Cal Anti-Scale



Cartucho Cerámico Ceramic Cartridge



12u./Caja 12u./Box



Conexiones flexibles Certified flexible



Montura cerámica Ceramic cartridge



Fácil montaje Easy assembly