

FICHA TÉCNICA

KASTILA

BATERÍA BAÑO-DUCHA

Color: Cromo



CÓDIGO: 102004001

Montura cerámica

Apertura ¼ vuelta

Flexo 1,7m-Mango-Soporte

Peso: 1,23 Kg.

Peso embalaje: 2,49 Kg.

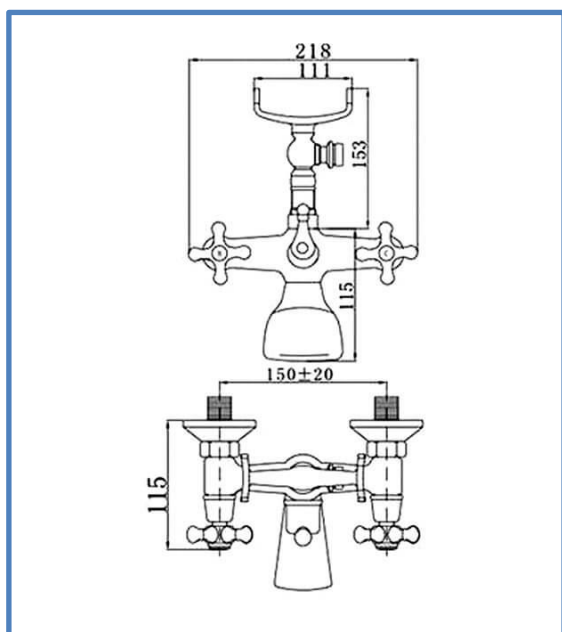

Designed in Europe



Anti-Cal Anti-Scale



Cartucho Cerámico Ceramic Cartridge



12u./Caja 12u./Box



Conexiones flexibles Certified flexible



Montura cerámica Ceramic cartridge



Fácil montaje Easy assembly