

FICHA TÉCNICA

KELENA

MONOMANDO BAÑO-DUCHA

Color: Cromo



CÓDIGO: 102006001

Cartucho cerámico 35mm

Apertura suave

Flexo 1,7m-Mango-Soporte

Peso Grifo: 1,26Kg

Peso embalaje: 2,05Kg

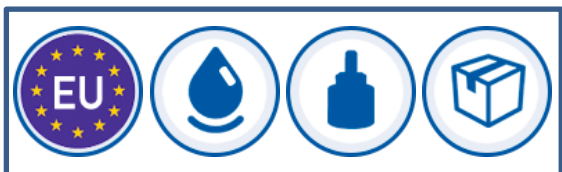
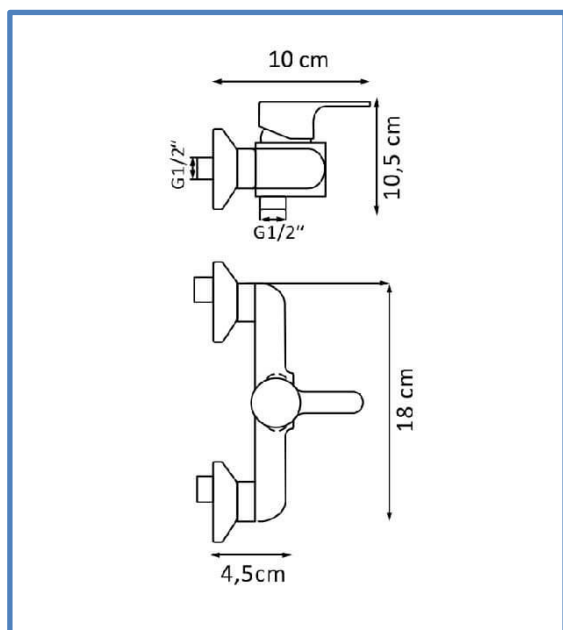

Designed in Europe



Anti-Cal Anti-Scale



Cartucho Cerámico Ceramic Cartridge



12u./Caja 12u./Box



Conexiones flexibles Certified flexible



Montura cerámica Ceramic cartridge



Fácil montaje Easy assembly